

Project: _____

Reference type: _____

Item code: _____

Date: _____

Notes: _____

CBU-A2D

Bluetooth controllable 2ch 0-10V/DALI controller

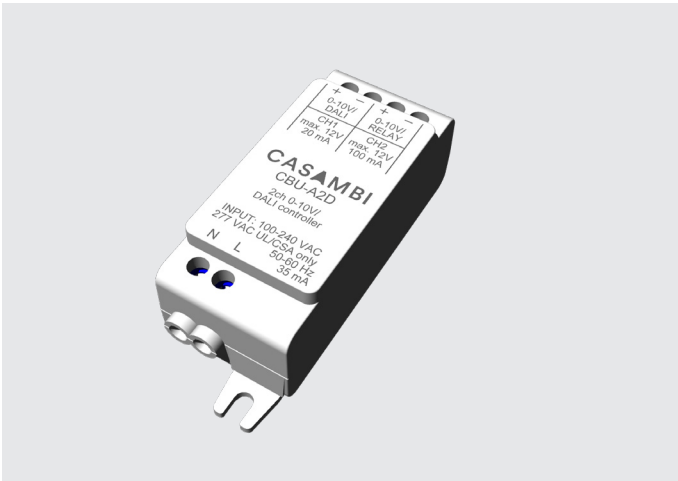

Dimensions

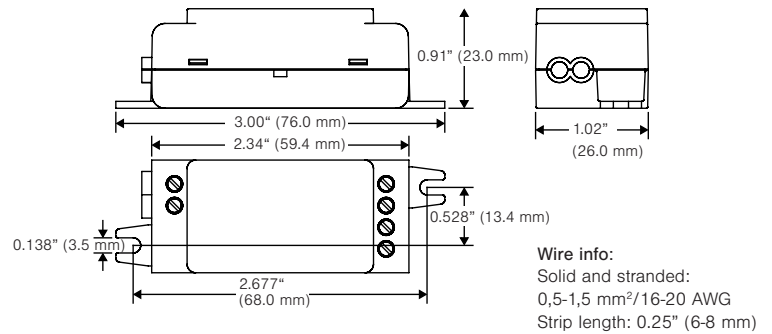

Dominant dimensions given in mm.

Description

CBU-A2D is a Bluetooth controllable, Casambi enabled 2 channel 0-10V/DALI controller. CBU-A2D has a universal 100-277 VAC input voltage range.

CBU-A2D can control one or two 0-10V controllable LED drivers, or it can control a tunable white LED driver with two 0-10V control interfaces. The product can also be configured into a DALI mode where it can be connected to a DALI LED driver or DALI sensor for presence and/or daylight harvesting functions.

CBU-A2D can be controlled with Casambi app which can be downloaded free of charge from Apple App Store and Google Play Store.

Different Casambi enabled products can be used from a simple one luminaire direct control to a complete and full featured light control system where up to 250 units form automatically an intelligent mesh network.



Warning!

Hazardous voltages. Risk of electric shock or fire. Only qualified professionals should make the connections. Disconnect the mains power supply and verify its absence prior to installation.



Project: _____

Reference type: _____

Item code: _____

Date: _____

Notes: _____

Technical data

Input

Voltage range: 100-240 VAC (CE/UL/CSA)
277 VAC (UL/CSA only)

Frequency: 50-60 Hz

Max. mains current: 35 mA

No-load standby power: < 0,5 W

Channel 1 output

Output voltage, 0-10V: 0-10 VDC, max. 7 mA (sinking)

Output voltage, DALI: 12 VDC, max. 20 mA (sourcing)

Maximum number of drivers: 1 driver + 1 sensor/push button

Channel 2 output

Output voltage, 0-10V: 0-10 VDC, max. 7 mA (sinking)

Output voltage, relay control: 12 VDC, max. 100 mA (sourcing)

Maximum number of drivers: 1

Radio transceiver

Operating frequencies: 2401...2483 MHz

Maximum output power: -4 dBm

Operating conditions

Ambient temperature, ta: -4...+113°F (-20...+45°C)

Max. case temperature, tc: +158°F (+70 °C)

Storage temperature: -13...+158°F (-25...+70 °C)

Max. relative humidity: 0...80%, non-cond.

Connectors

Wire range, solid & stranded: 0,5-1,5 mm² /
16-20 AWG

Wire strip length: 6-7 mm (.25")

Tightening torque: 2,6 Lb-In/0,4 Nm

Mechanical data

Dimensions: 76,0 x 26,0 x 23,0 mm
3.0 x 1.0 x 0.9 inch

Weight: 40 g (1.39 oz)

Degree of protection: IP20 (indoor use only)

Protection class: Built-in Class II

FCC ID: 2ALA3-CBUA2D

IC: 22496-CBUA2D

UL: E494741

Range

The range between two CBU-A2D units or between a CBU-A2D and a smart phone can vary a lot depending on obstacles and surrounding material. In open-air the range between two CBU-A2Ds is 200 ft, but surroundings may affect the range, so testing is highly recommended.

Casambi uses mesh network technology so each CBU-A2D acts also as a repeater. When testing the network, it is important to test that each unit can be controlled from any point of the network covered area.

Compatible devices:

iPhone 4S or later
iPad 3 or later
iPod Touch 5th gen or later
Android 4.4 or later devices produced after 2013
with full BT 4.0 support

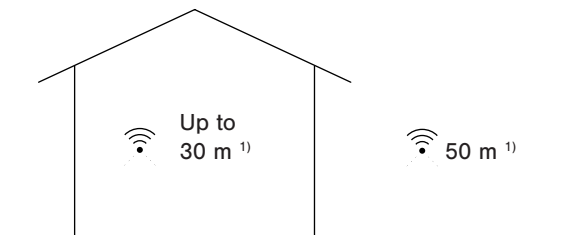

1) Range is highly dependant on the surrounding and obstacles, such as walls and building materials.

Project: _____

Reference type: _____

Item code: _____

Date: _____

Notes: _____

Installation

Make sure that the mains voltage is switched off when making any connections. Use 16-20 AWG (0.5-1.5 mm²) solid or stranded conductor electrical wires. Strip the wire 0.25" (6-7 mm) from the end. Insert the wires into the corresponding holes and tighten the connector screws.

If the connected LED driver cannot be turned off completely from the control interface, an external relay with 12 VDC coil can be connected to channel 2. Make sure the relay is protected against flyback voltage, e.g. do not use a PCB relay without the flyback diode. A suitable fixture configuration must be selected in order to control a relay.

Wiring diagram, Push Button

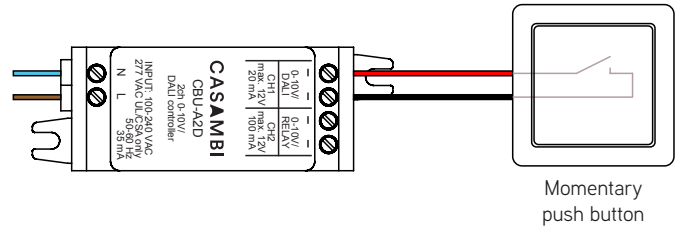

Wiring diagram, 2 channel LED driver

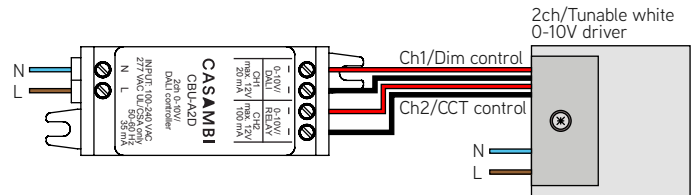

Wiring diagram, one driver and relay

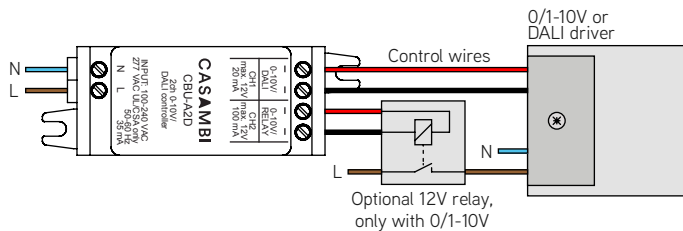

Wiring diagram, DALI sensor

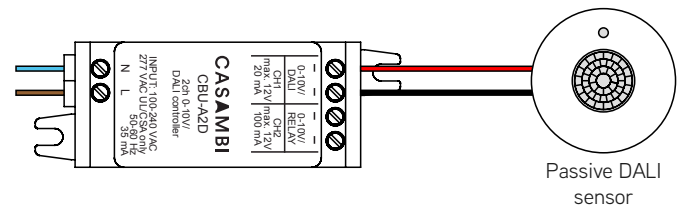

Wiring diagram, two drivers (only 0-10V)

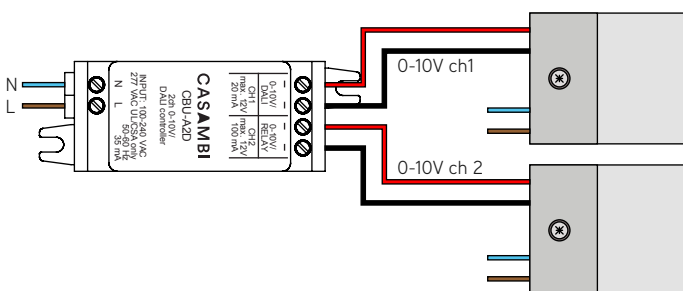

Warning

Do not connect the output channels in parallel. This may cause permanent damage to the product.

Changes or modifications not expressly approved by Casambi Technologies Oy could void the user's authority to operate the equipment.

Project: _____

Reference type: _____

Item code: _____

Date: _____

Notes: _____

Compliance Statement

This device complies with part 15 of the FCC Rules. Operation is subject to the following two conditions:

- (1) This device may not cause harmful interference, and
- (2) this device must accept any interference received, including interference that may cause undesired operation.

Radiation Exposure Statement for FCC

This device complies with FCC radiation exposure limits for an uncontrolled environment. This device shall be installed and operated with a minimum distance of 0.8" (2cm) between users or bystanders and the device.

FCC Interference Statement

This equipment has been tested and found to comply with the limits for a Class B digital device, pursuant to Part 15 of the FCC Rules. These limits are designed to provide reasonable protection against harmful interference in a residential installation.

This equipment generates, uses and can radiate radio frequency energy and, if not installed and used in accordance with the instructions, may cause harmful interference to radio communications.

However, there is no guarantee that interference will not occur in a particular installation. If this equipment does cause harmful interference to radio or television reception, which can be determined by turning the equipment off and on, the user is encouraged to try to correct the interference by one of the following measures:

- Reorient or relocate the receiving antenna.
- Increase the separation between the equipment and receiver.
- Connect the equipment into an outlet on a circuit different from that to which the receiver is connected.
- Consult the dealer or an experienced radio/TV technician for help.

Radiation Exposure Statement for Canada

This device complies with Industry Canada's licence-exempt RSSs.

Operation is subject to the following two conditions:

- (1) This device may not cause interference
- (2) This device must accept any interference, including interference that may cause undesired operation of the device.

This equipment is exempt from the routine RF exposure evaluation requirements of RSS-102. This equipment should be installed and operated with a minimum distance of 20 cm between the antenna and the user or bystanders.

Le présent appareil est conforme aux CNR d'Industrie Canada applicables aux appareils radio exempts de licence. L'exploitation est autorisée aux deux conditions suivantes:

- (1) l'appareil ne doit pas produire de brouillage;
- (2) l'utilisateur de l'appareil doit accepter tout brouillage radioélectrique subi, même si le brouillage est susceptible d'en compromettre le fonctionnement.

Ce matériel n'est pas sujet à l'évaluation habituelle d'exposition RF selon RSS102. Ce matériel devrait être installé et exploité en gardant une distance minimale de 20 cm entre l'antenne et l'utilisateur ou les spectateurs.

NOTES